

TAG, TAW外形尺寸

| 型号 代号 | TAG-09 | TAG-11 | TAG-13 | TAW-13 | TAW-17 |
|----------|--------|--------|--------|--------|--------|
| L1 | 185 | 223 | 257 | 290 | 394 |
| L2 | 280 | 350 | 400 | 580 | 788 |
| B1 | 57 | 72 | 83 | 82.5 | 119 |
| B2 | 48 | 60 | 73 | 50 | 60 |
| B3 | 155 | 202 | 225 | 202 | 272 |
| B4 | 114 | 143 | 165 | 165 | 235 |
| H1 | 16 | 28 | 28 | 32 | 32 |
| H2 | 78 | 85 | 110 | 135 | 140 |
| H3 | 188 | 216 | 241 | 292 | 340 |
| d1 | 65 | 90 | 140 | 140 | 190 |

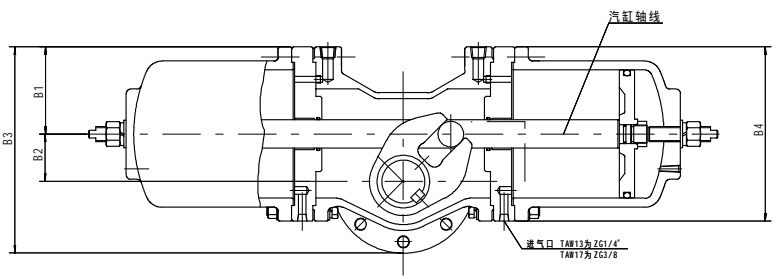
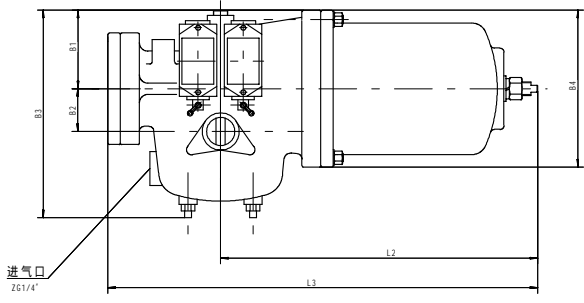

TAG, TAW 连接型式尺寸

| 代号 型号 | 代号 | d1 | d2 | d3 | d4 | h1 | h2 | h3 | h4 | b | L |
|----------|-------|------------------------|---------------------------|-----------------|-------|----|----|----|----|------------------|------------------|
| TAG-09 | G09-1 | 90 | $12.6^{+0.035}_0$ | 57 | 4-M6 | 10 | 2 | 36 | 35 | 3 ± 0.015 | $14^{+0.1}_0$ |
| | G09-2 | | $12^{+0.059}_0$ | 55 | | | | | | 4 ± 0.015 | $13.8^{+0.1}_0$ |
| | G09-3 | | $22^{+0.072}_{-0.020}$ | 50 | | | | | | 6 ± 0.015 | $24.8^{+0.1}_0$ |
| TAG-11 | G11-1 | 95 | $15.8^{+0.035}_0$ | 69.85 | 4-M10 | 17 | 2 | 36 | 35 | 5 ± 0.015 | $18.1^{+0.1}_0$ |
| | G11-2 | | $16^{+0.059}_0$ | 72 | 4-M8 | | | | | $18.3^{+0.1}_0$ | |
| | G11-3 | | 75 | $18.8^{+0.1}_0$ | | | | | | | |
| | G11-4 | | $20^{+0.072}_{-0.020}$ | 72 | 4-M10 | 17 | 2 | 36 | 35 | 6 ± 0.015 | $22.8^{+0.1}_0$ |
| | G11-5 | | $18.9^{+0.045}_0$ | 69.85 | | | | | | 5 ± 0.015 | $21.2^{+0.1}_0$ |
| | G11-6 | | $19^{+0.072}_{-0.020}$ | 75 | | | | | | 6 ± 0.015 | $21.8^{+0.1}_0$ |
| | G11-7 | | $28^{+0.072}_{-0.020}$ | 70 | | | | | | 4-M8 | 14 |
| TAG-13 | G13-1 | 140 | $22^{+0.072}_{-0.020}$ | 90 | 4-M12 | 20 | 3 | 47 | 45 | 6 ± 0.015 | $24.8^{+0.1}_0$ |
| | G13-2 | | $22.1^{+0.045}_0$ | 88.9 | | | | | | 5 ± 0.015 | $24.4^{+0.1}_0$ |
| TAW-13 | W13-1 | 140 | $28.45^{+0.072}_{-0.020}$ | 88.9 | 4-M12 | 20 | 3 | 47 | 50 | 8 ± 0.03 | $31.75^{+0.2}_0$ |
| | W13-2 | | 31.6 ± 0.051 | | | | | | | $34.9^{+0.2}_0$ | |
| | W13-3 | $28^{+0.072}_{-0.020}$ | 140 | $31.3^{+0.2}_0$ | | | | | | | |
| | W13-4 | 90 | $35.3^{+0.2}_0$ | | | | | | | | |
| | W13-5 | $32^{+0.087}_{-0.025}$ | 108 | $34.9^{+0.2}_0$ | | | | | | | |
| | W13-6 | $31.6^{+0.045}_0$ | 140 | $47^{+0.2}_0$ | | | | | | | |
| TAW-17 | W17-1 | 190 | $42^{+0.072}_{-0.020}$ | 160 | 4-M16 | 30 | 7 | 70 | 30 | 10 ± 0.05 | $43^{+0.2}_0$ |
| | W17-2 | | $38^{+0.072}_{-0.020}$ | 158.75 | | | | | | $38.15^{+0.2}_0$ | |
| | W7-3 | | $33.15^{+0.072}_{-0.020}$ | | | | | | | $38.15^{+0.2}_0$ | |

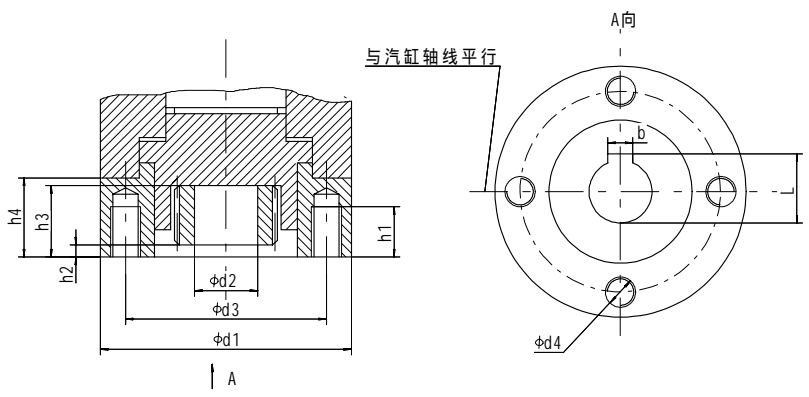

| | | | | | |
|----------|----|------------|----|-----------|----|
| TAG, TAW | | 部分回转阀门气动装置 | | 外形及连接型式尺寸 | |
| 图号 | 比例 | 数量 | 日期 | 设计 | 审核 |
| 材料 | 数量 | 日期 | 设计 | 审核 | 日期 |
| 天津市阀门公司 | | | | | |